

The ECM Textbook

Table of Contents

- Overview of ECM Technology
- Indoor Blower Motors
 - o Variable Speed ECM
 - o Constant Torque ECM

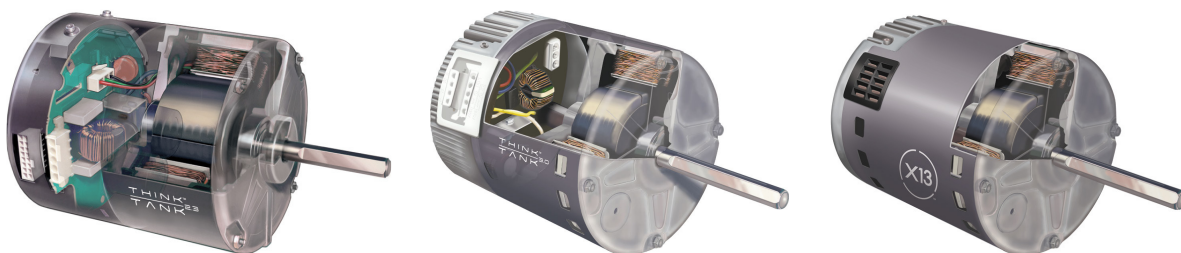

www.theDealerToolbox.com



ecm | capacitors | blowers | motors

About the Company

When Regal Beloit acquired General Electric's Commercial and HVACR Motors and Capacitors businesses in 2004, it also acquired the rights to use the GE brand through 2009. With this rebranding, the Genteq logo will take the place of GE ECM, GE Commercial Motors and GE Capacitors logos on all branded products. For more information on the brand change please visit www.GenteqMotors.com.

This material has been created and distributed for the purpose of education and to encourage best practices of the HVAC industry. The integrity of the industry we share is the responsibility of every one working in it including its educators to uphold the faith of the consumers who put their trust in us as professionals.



**Genteq™
1946 Cook Road
Fort Wayne, IN 46818
260-416-5400
copyright@theDealerToolbox.com**

“The ECM Textbook” © Copyright 2010

The text and images in this document are not to be modified without express written permission of Genteq. This document as a whole may be reproduced and distributed, but not sold, for educational purposes. This document as a whole may be included in the bulk of other education material that is for sale with express written permission of Genteq.

**Please direct any questions on permission to use the text or images included in this material to:
copyright@theDealerToolbox.com**

Overview of ECM Technology

What is ECM technology? ECM (Electronically Commutated Motor) technology is based on a brushless DC permanent magnet design that is inherently more efficient than the shaded-pole and permanent-split-capacitor (PSC) motors commonly found in air handlers, furnaces, heat pumps, air conditioners and refrigeration applications throughout the HVACR industry. By combining electronic controls with brushless DC motors, ECM's can maintain efficiency across a wide range of operating speeds. Plus, the electronic controls make the ECM programmable, allowing for advanced characteristics that are impossible to create using conventional motor technologies.



Early HVAC literature listed these motors as **ICM (Integrated Control Module)**, meaning that a control was integrated or used in conjunction with a motor to control its operation. This was later changed to **ECM (Electronically Commutated Motor)** as they are typically referred to today. The definition of commutate is to reverse the direction of an electric current (the means by which all electric motors rotate). In an ECM this process is controlled electronically by a microprocessor and electronic controls, which provides the ability to increase or decrease the speed of the motor.

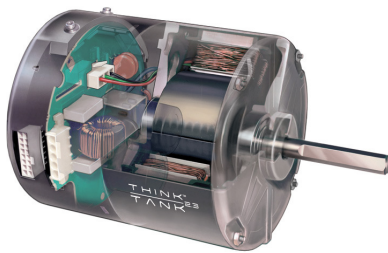

The Genteq™ motor, currently used by most residential HVAC systems is a brushless DC, three phase motor with a permanent magnet rotor. Motor phases are sequentially energized by the electronic control, powered from a single phase supply. These motors are actually made of two components, a motor control (control module) and a motor, sometimes called a motor module.

Motor Control (Control Module)

Motor (Motor Module)

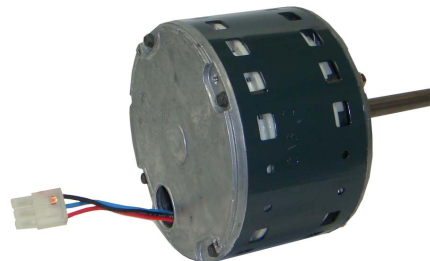

The motor control is the brains of the device, where single phase (1Ø) 120 or 240 VAC 60 cycle (Hertz/frequency) power is connected. The control then converts AC power to DC power to operate the internal electronics, thus the name DC motor. The microprocessor in the motor control is programmed to then convert DC power (by means of electronic controls) to a three phase (3Ø) signal to drive the motor, thus the name three phase motor. It also has the ability to adjust the frequency (which controls the speed in revolutions per minute) and the level of current (power) it delivers to the motor.



The motor is essentially a three phase motor with a permanent magnet rotor. The permanent magnet rotor contributes to the electrical efficiency of the ECM and also to its sensor-less ability to control the rpm (revolutions per minute) and commutation (when to alternate the cycle). Typical DC motors require brushes to provide the commutation function. This is where the ECM motor gets the name brushless DC motor.

The benefit of all of this technology is increased electrical efficiency and the ability to program more precise operation of the motor, over a wide range of HVAC system performance needs, to enhance consumer comfort.

Variable Speed ECM

The term **Variable Speed Motor** was coined back in the late 1980's when the first indoor blower ECM's were introduced to the residential HVAC industry (split systems and package systems 5 ton or less). By function they are also called **Constant Airflow Motors**. Both of these terms define the type or style of ECM it is programmed to function as.

This motor was originally produced by three manufacturers, AO Smith, Emerson, and GE. Since the early 1990's most manufacturers have used the Genteq motor in their variable speed products. The brand name for this motor is the Think Tank™ which covers models ECM 2.0, 2.3, 2.5 and 3.0.



ECM 2.0



ECM 2.3/2.5



ECM 3.0

The three main benefits of this motor over conventional induction motors (PSC) include higher efficiency, more precise and unlimited airflow selection (variable speed), and properly maintained airflow during changes in system static pressure (constant airflow).

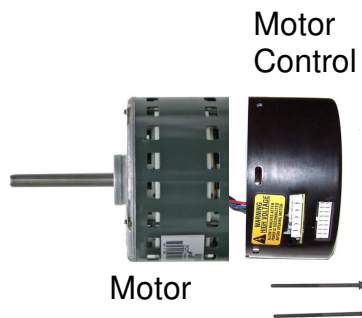

The Genteq variable speed is actually built as two separate components. The control module (motor control) is attached to the back of the motor module (motor). The variable speed motor control is programmed to provide constant airflow. This is accomplished by converting the desired CFM to a specific amount of speed (RPM) and torque (current) delivered to the motor.

Each HVAC OEM (Original Equipment Manufacturer) creates a special program unique to the model and size unit the variable speed ECM will be used in. This program provides multiple airflow and comfort options for each demand of the system the motor is installed in, and any of the possible connected components.

To summarize, the variable speed motor is operated by two programs. The HVAC OEM program determines what amount of airflow is needed by demand and the constant airflow program makes sure that selected amount of airflow is maintained even if external static pressure changes.

Operation

The variable speed ECM is a dual voltage motor. The 120VAC or 240VAC single phase power is supplied through the 5-pin connector to the motor at all times, even if there is no demand for airflow. This power is what operates the internal electronics and drives the motor. The low voltage or serial communication that is sent to the motor from the HVAC OEM control board through the 16-pin connector (4-pin on latest model 3.0) is a combination of the HVAC OEM programming, the installer's selections of airflow and comfort settings and the current demand of the system (heat, cool, fan...). This is the information the motor control requires to determine how much torque and speed the motor will need for proper airflow of each system demand.



During each demand the motor control also monitors the actual speed in revolutions per minute (RPM) of the motor. There is only one combination of torque and speed that will create the proper amount of CFM demanded at a specific total external static pressure (ESP) of the system. If the speed/torque relationship is incorrect for the required airflow, the motor control can increase or decrease the torque (current) to the motor. This will in turn increase or decrease the speed of the motor to maintain airflow. By constantly monitoring the actual speed of the motor, and maintaining the torque/speed relationship programmed by the HVAC OEM, the motor control is able to maintain the airflow selection per demand if ESP changes.

Three very important points must be understood about this ability of the motor:

1. The motor will use more energy to maintain airflow when ESP is higher than the HVAC OEM recommended, and the air noise of the system may be increased.
2. The motor will use less energy to maintain airflow when ESP is equal to or less than the HVAC OEM recommendation and the air noise of the system will be decreased.
3. The motor has a programmed limit of operation to protect itself from damage, due to the energy (current) it must use to maintain airflow at high external static pressures. See the HVAC OEM literature for their recommended maximum total ESP. If the system exceeds this recommendation, airflow may not be maintained, however, the motor will still try to deliver as much air as possible, without causing damage to itself.

Application

Variable speed motors are typically found in two-stage, multi-stage and modulating high end furnaces (80+% & 90+% AFUE), air handlers, package systems and also in geothermal systems.

Benefits

Constant airflow is the ability of the variable speed motor to maintain it's programmed and field selected airflow per demand, when ESP is higher than recommended and/or changes during system operation. ESP (the resistance to the movement of air) is increased when ductwork is undersized, poorly constructed and/or full of dirt or debris. ESP can increase during system operation when dirt builds up on the air distribution systems components, especially the filter, and when customers close or block grilles and registers. The variable speed motor is programmed to maintain airflow during all of these situations, within the limits of the HVAC OEM programming and motor design. On PSC induction motor systems, airflow will decrease when ESP increases.

When set up correctly the benefits of the variable speed motor system include:

- Energy savings
- Improved outlet air temperature for each system demand
- Improved humidity control
- Improved system capacity
- Reduced space temperature swings
- Reduced air noise with soft start/stop and gradual changes between airflow demands, delays and/or profiles
- Reduced constant fan air noise with low CFM settings plus increased energy savings over normal system operation
- Reduced repairs associated with continuous low airflow operation

Installation/Set-up

After the system is installed, the technician must follow the HVAC OEM manuals to set the proper airflow and comfort settings to match the components and operation desired as installed. These are typically selected by use of jumper pins, dip switches and/or multi-pin plugs on the HVAC OEM control board in the system. There are also systems in the marketplace that are able to adjust many of these selections at the user interface (in these systems, the user interface replaces the thermostat as a communication center for the system). If these selections are not set at the time of installation, there is a good chance the system will not perform as expected and/or not produce the designed capacity. In addition the system may be prone to problems and/or premature parts failures.

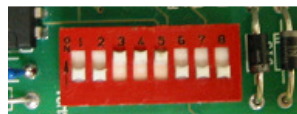

Rotary Switch for Delay Time



Rotary Switch for Cooling Tonnage



Model Plugs for Heating Selection

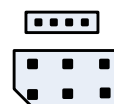

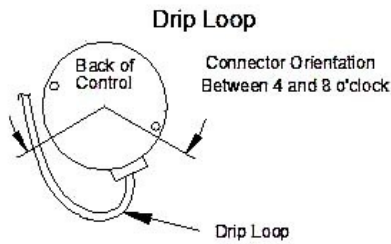

It is recommended that the electrical connections on the ECM face down or between the 4 and 8 o'clock positions, and a drip loop formed out of the wiring harness leaving the motor. This is to prevent any moisture or water that may get into the motor area from running into the connectors where it could cause damage to the control. In most systems, the HVAC OEM will install the motor in the correct position and provide the drip loop. However, when multi-position systems are installed in a position other than the manufactured position, the motor may need to be turned and the drip loop re-arranged.

The total external static pressure (ESP) of the installed system should be measured and compared to the HVAC OEM charts. If it is above the maximum listed for that unit, improvements should be made to lower it. Any total ESP below the maximum is typically acceptable. However, system efficiency, noise levels and potential service issues will all be improved when the total ESP is as close to the HVAC OEM recommendation as possible. HVAC OEM installation manuals provide guidelines that should be followed per unit for best performance. Some important examples of the guidelines found in these manuals include filter sizing charts, proper duct connections and unit cut-outs. On fossil fuel systems, the temperature rise should always be measured and corrected if not within the HVAC OEM rating on the data plate of that unit.

Note: Water damage is one of the most reoccurring failures with electrical components. Always construct and size the condensate drains and traps by the HVAC OEM specifications.

Troubleshooting (Genteq variable speed motors only)

Before troubleshooting any HVAC system, it's a good practice to become familiar with the components and wiring diagram, check for and follow any on board diagnostics (HVAC OEM system fault codes). On variable speed systems it's also a good practice to check the airflow, comfort and delay settings. The HVAC OEM manuals will typically be required for these settings and can also provide valuable sequence of operation and troubleshooting help.

If the motor is running but the system is noisy, shutting down on its limits or safeties or the evaporator coil is freezing, there is a good chance the motor is good. The problem is most likely external to the motor.

- Check the airflow settings using the HVAC OEM guide
- Check the air distribution system components for dirt load and closed dampers, registers and grilles.
- Measure the total external static pressure and make repair(s) if above the HVAC OEM recommended maximum level. Aftermarket filter sizing is a common issue.

If the motor is not running, the following checks will diagnose whether it is operational. **Always disconnect the power to the HVAC system before disconnecting or reconnecting any connectors to these motors.** There are two inputs needed to operate this motor, a high voltage constant power source, and the communication that selects the airflow requirement per demand. All of the connectors/plugs used with this motor are keyed for proper orientation. If connected improperly the motor may not operate properly and/or be damaged.

- **Checking the high voltage input**

First check the high voltage to the 5-pin connector. There should be 120VAC or 240VAC depending on the system at terminals 4 and 5 whenever there is power to the system, regardless of a demand call. On 120VAC systems, make sure the polarity of the connected power to the motor is correct. If this voltage is missing, fix the problem in the system and try to run the motor. If the voltage is within $\pm 15\%$ of these ratings then move on to the next step. If the voltage is above or below the $\pm 15\%$ of these ratings, fix the voltage problem first, and try to run the motor. Proper grounding should always be checked and repaired if needed.

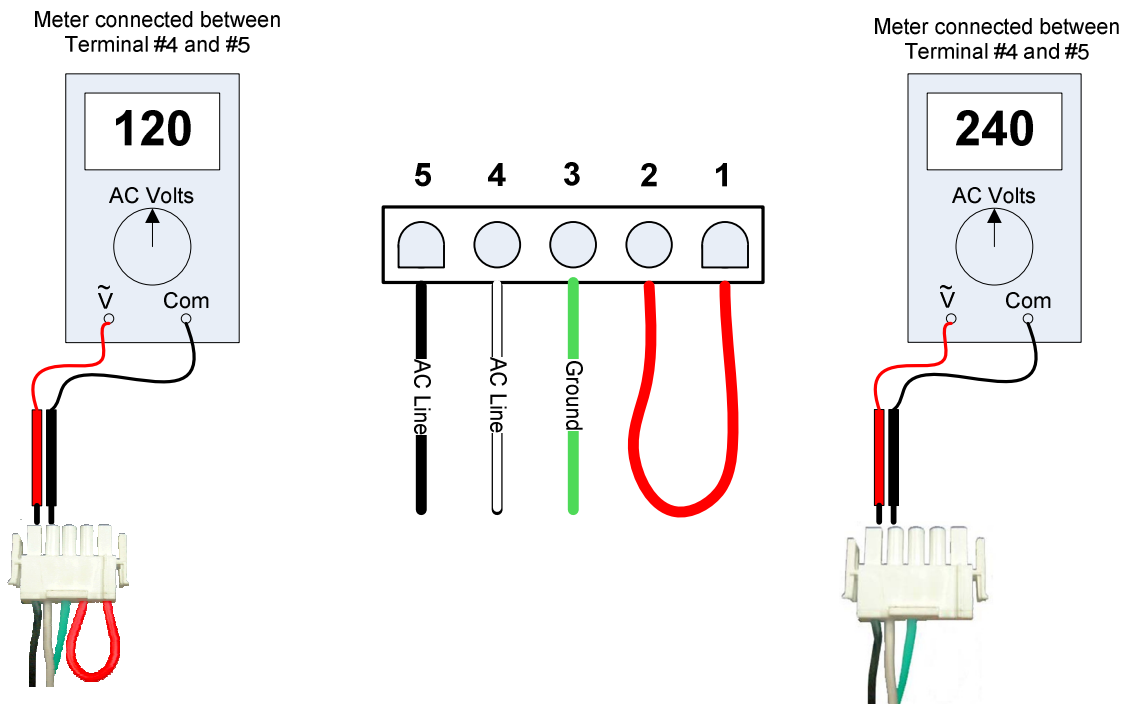

120VAC motors must have a jumper between terminals 1 and 2 for proper operation.

240VAC motors should not have a jumper between terminals 1 and 2 to prevent damage to the motor.

- **Checking the communication input**

To check the communication to the motor on the 16-pin connector (4-pin connector on the latest model 3.0) you will need the systems OEM manual showing by pin what voltage/communication should be present per demand. This voltage could be AC, DC and/or serial communication. Some HVAC OEM's provide troubleshooting tools for use on their motors. Genteq also has a troubleshooting tool for this purpose that will work on all of their variable speed motors in all HVAC OEM systems (with the exception of the model 2.5 motor). This tool is called the TECMate PRO. This device will simulate a communication signal to the motor. The TECMate PRO is available at most distributors as well as our website www.theDealerToolbox.com.

Begin set-up with the TECMate PRO switch in the off position.

- The TECMate PRO has two wires with alligator clips for connection to a 24vac power supply (they are not polarity sensitive). The green led on the TECMate PRO will turn on when properly connected to 24vac. The 16-pin connector from the TECMate PRO is connected to the motor in place of the HVAC OEM 16-pin harness (4-pin connector on the latest model 3.0). The 5-pin high voltage connector must be connected to the motor with its power confirmed and the system power turned on (after all of these connections are completed) for this test.

If the motor runs when the TECMate PRO switch is turned on, the problem is before the motor in the HVAC system. If the motor does not run with the TECMate PRO, then the motor control is failed and will need to be replaced. The motor, however, may still be good.

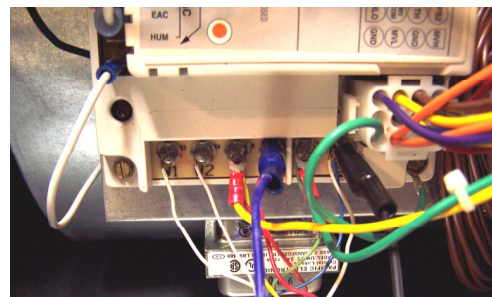
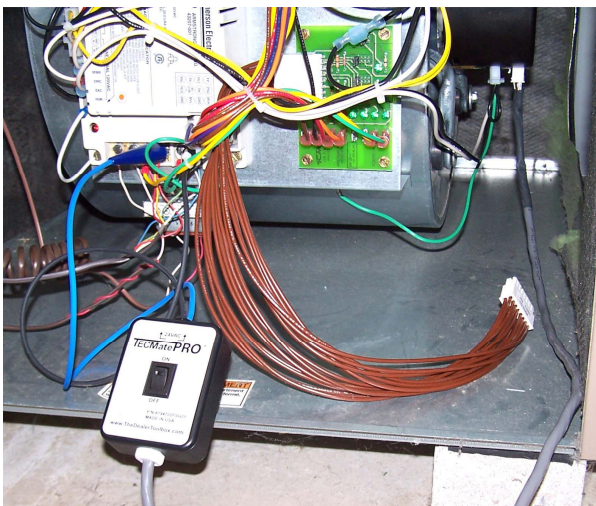

**5-pin
Connector
Re-installed**

**TECMate
16-pin
Connector**

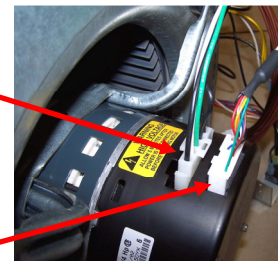

To check the motor separately from the motor control, turn off the main power and disconnect the high voltage 5-pin connector and the communication 16-pin connector (4-pin connector on the latest model 3.0). **There must be at least 5 minutes elapsed time between when the power was disconnected and the next step.** Remove the two ¼" hex head bolts from the end of the control module and carefully separate it from the motor module. Unplug the 3-pin connector between the control module and the motor.

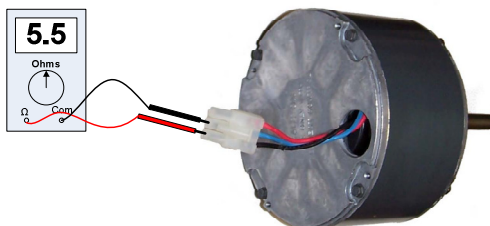
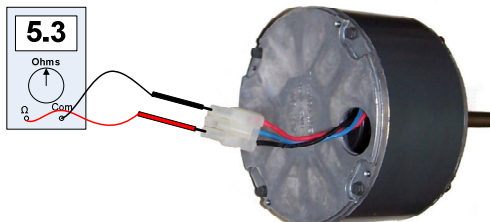
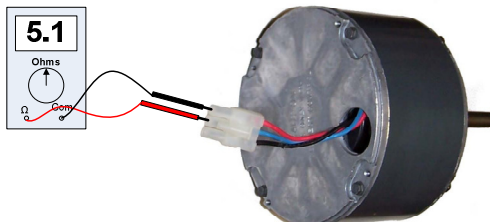
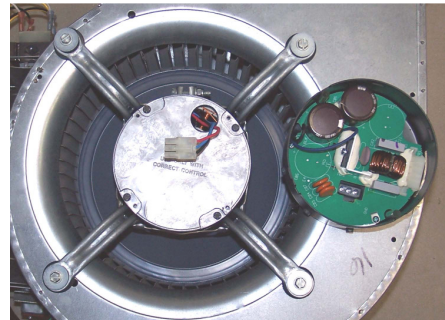
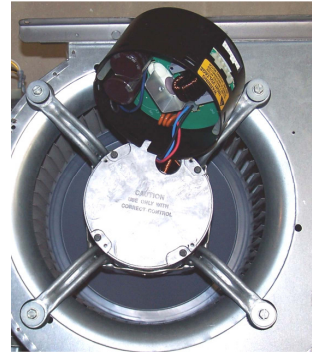
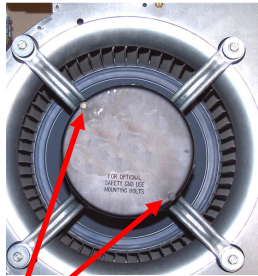
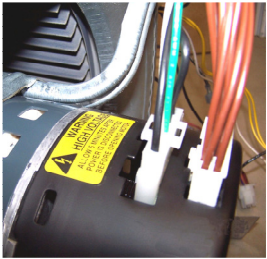

Perform the following ohm tests on the motor through the 3-pin connector.

- Ohm out the phases from one terminal to the other in the connector. Set the meter to the lowest ohms scale. If the readings are all less than 20 ohms and within $\pm 10\%$ of each other, the motor passes this test. If not, the motor is failed and must be replaced.

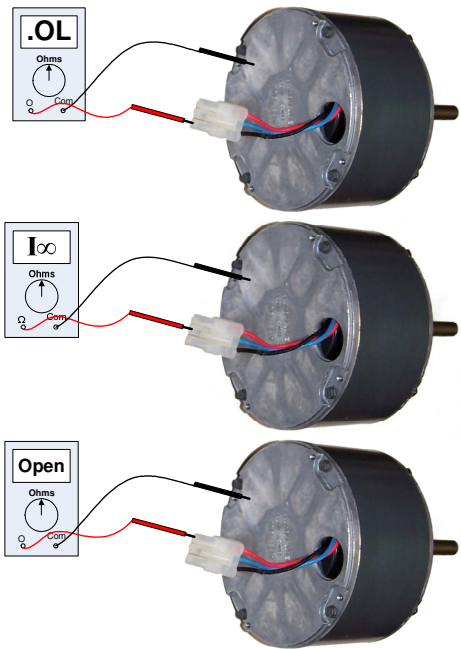

- Ohm out the motor windings from each terminal in the connector to ground, the face of the motor (X-brace on the model 3.0). Set the meter to the highest ohms scale (no meg-ohm meters). If all of these readings are above 100,000 ohms, the motor is good. Typically a good motor will show all readings as Infinity (I), (O.L.), or (Open). If any of these readings is below 100,000 ohms, the motor is failed and must be replaced.

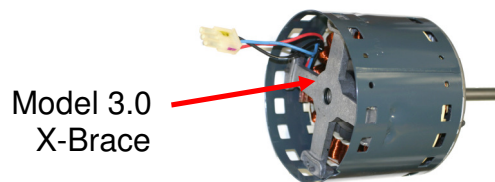

Repair

The variable speed ECM has a unique program for each HVAC OEM model and size unit it is used in. Replacement control modules and/or motor modules must be an exact match to the system they were removed from. There are no universal replacement controls or motors. Using the wrong parts voids all product warranties and may produce unexpected results. Always follow all instructions included with the replacement motor and/or control.

If only the motor control needs to be replaced (the motor passes both ohms tests), the motor can stay in its mount, in the blower section. The new control will install just as the old one was removed. If the entire motor must be replaced, (motor control and motor module) it's easier to install the motor fully assembled. Belly band mounting brackets should only make contact with the motor, not the motor control, and should not cover any motor vents. The connectors should be facing down when the blower section is in the system and the wires leaving the motor should be formed into a drip loop. If there is any sign of water damage on the old motor or control, correct the water issue.

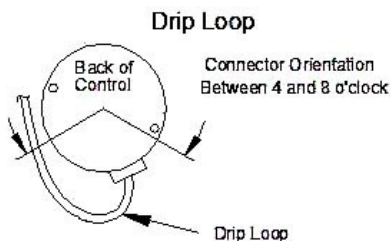
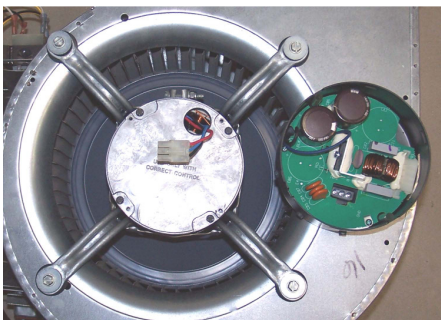

The variable speed ECM may rock back and forth when it first turns on. This is normal operation for the control to figure out the proper direction to operate the motor.

Always check the wiring and proper operation of the entire system (including system safeguards) after all service and repair work.

Conclusion

The variable speed motor produced by Genteq ECM is currently in its 6th generation. Reliability improvements over these generations include:

- Fully encapsulated electronics to protect against moisture damage
- Improved EMI filter to provide protection against line transient (voltage spikes)
- Speed limiting to prevent over-current operation due to extremely high external static pressure operation
- Durable ball bearings on all models



With proper installation, set-up and annual system maintenance, these motors are providing proven reliability in today's high end HVAC systems.

The HVAC OEM has almost limitless ability to choose the amount of airflow, on/off delays, and comfort profiles for each demand of the system. It is imperative that the contractor consult installation and service manuals to set up the system properly and take advantage of all of its capabilities. Attending the HVAC OEM classes on variable speed products, as with all products, is also highly recommended.

Constant Torque ECM

Genteq introduced the **Constant Torque** motor (model X13) to the residential HVAC industry (split systems and package systems 5 ton or less) in 2006. The term “Constant Torque” defines the type or style of ECM it is programmed to function as.

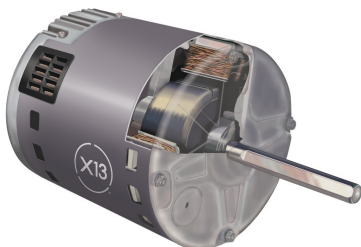

The X13 is constructed as one piece, with the two components of any ECM, the motor control and motor, housed inside one motor shell. It is programmed to provide a constant level of torque (current/power) to the motor. This is a multi-tap motor with the ability to have from 1 to 5 programmed levels of torque, similar to the speeds of a PSC induction motor. However, the torque value programmed into each tap is determined by the HVAC OEM (Original Equipment Manufacturer). Each value equals a specific amount of torque to create the proper amount of airflow for each system demand (heat, cool, constant fan). This value is also specific and unique to each HVAC OEM, model and size system.

To summarize, the X13 motor is operated by two programs. The HVAC OEM programmed torque value determines what amount of torque is needed by demand and the constant torque programming makes sure that selected amount of torque is maintained even if external static pressure (ESP) changes.

The three main benefits of this motor over conventional induction motors (PSC) include higher efficiency, more precise airflow, and properly maintained torque during changes in the systems external static pressure (constant torque).

Operation

The X13 motor is available in three models, 115VAC, 230VAC and 460VAC (Introduced in 2009). The high voltage connections to the motor are the same regardless of which voltage model is used. Those terminals are labeled (L), (G), and (N).

115VAC model (L) = L1 115VAC	(G) = Ground	(N) = Neutral
230VAC model (L) = L1 115VAC	(G) = Ground	(N) = L2 115VAC
460VAC model (L) = L1 277VAC	(G) = Ground	(N) = LC 277VAC

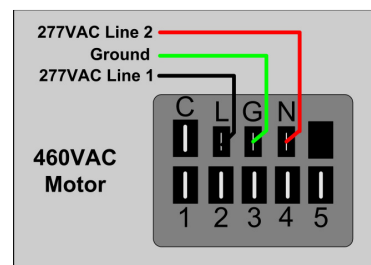
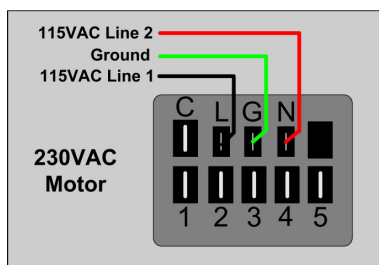
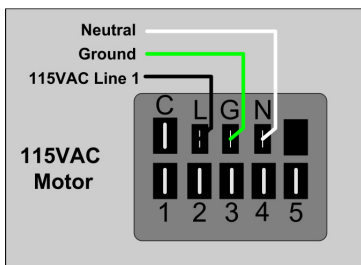

The high voltage is connected to the motor at all times. This power is what operates the internal electronics and drives the motor. However, this power will not operate the motor by itself; the motor requires a low voltage communication input to operate. The low voltage communication to the motor is delivered to taps 1-5 and the (C) terminal from the HVAC OEM control board or control relay. The X13 motor has the capability of accepting a communication signal of 9-23VDC as well as 24VAC on these taps. 24VAC is most commonly used. Instead of energizing a motor speed (winding) on a PSC motor for each demand (heat cool, constant fan); the communication voltage directs the motor to operate at the torque value stored in the tap it is connected to. The HVAC OEM will show which taps are to be selected for each demand, similar to selecting the speeds on a PSC motor.

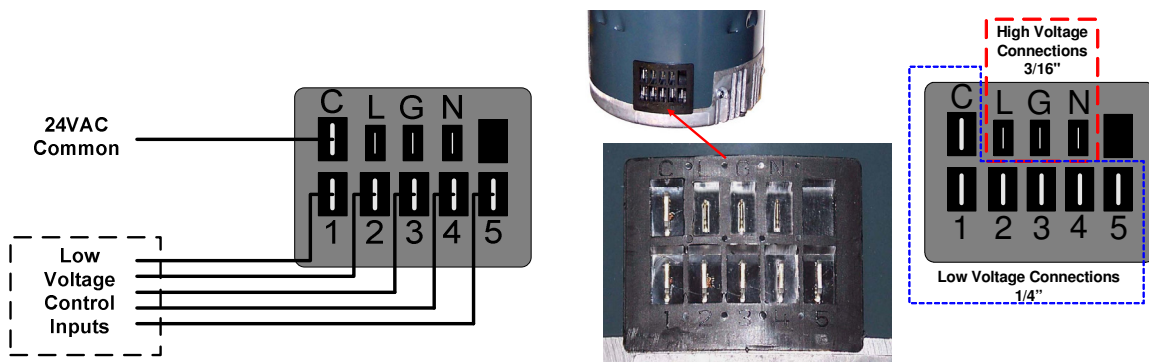

During each demand, the X13 motor will maintain the selected torque during changes in the systems external static pressure (constant torque). If ESP increases the motor will use more power (current) to maintain torque. The motor has a programmed limit of operation to protect itself from damage, due to the energy it must use to maintain torque at high external static pressures. If the systems maximum total ESP is exceeded, torque will not be maintained, however the motor will deliver as much torque as possible, without causing damage to itself.

The HVAC OEM can choose to wire this motor with individually wired terminals, connectors/plugs or both. Improper wiring may result in no operation, improper operation and/or damage to the motor.

Even though changing the low voltage tap connections does change the speed of the motor, it is important, in theory at least, to understand that these are programmed levels of torque. Referring to the taps as “speeds” or “speed taps” could be confusing if the following key points are not also understood.

- The HVAC OEM could program the taps in any order they choose. For example they could put the higher cooling airflow selection on Tap 1 and the lower heating airflow selection on Tap 2. Most manufacturers are programming the motor starting at Tap 1 and building in torque values respectively.

- Each tap can have a unique amount of torque programmed for a specific purpose. For example switching from Tap 1 to Tap 2 may very well increase the airflow but not necessarily at a specific interval like changing from low speed to medium low speed on a PSC motor would. Even more important, each motor has a unique program. Changing taps on one X13 motor will most likely have different results than any other.
- It is not necessary to program all of the taps. If the manufacturer only needs two functions, they may only program two taps, and so on up to five. All X13 motors will physically have 5 taps.
- Multiple taps could be energized by the HVAC OEM at the same time. Unlike a PSC motor, energizing multiple taps on the X13 will not harm the motor. The X13 will simply operate at the highest tap number, which will typically be the highest torque value.

Application

Most residential HVAC OEM are using the X13 motor in some of their split system air handlers and package systems, single stage applications. The X13 motor could also be used in gas and oil furnaces.

Benefit

Constant torque allows the X13 motor to maintain the torque (current) delivered to the motor when ESP is higher than recommended and/or changes during system operation. ESP (the resistance to the movement of air) is increased when ductwork is undersized, poorly constructed and/or full of dirt or debris. ESP can increase during system operation when dirt builds up on the air distribution systems components, especially the filter, and when customers close or block grilles and registers. When torque is maintained, airflow does not decrease as fast as it would on a PSC motor system. This decreases the effect ESP has on loss of airflow, providing better system performance and efficiency within the limits of the motor design.

The ability to program the torque value by demand allows the HVAC OEM to deliver more precise airflow and only program the amount of selections needed.

The X13 motor provides the energy savings of an ECM with the simplicity of traditional PSC motor set-up and service.

Installation/Set-up

The HVAC OEM may program only the taps needed for the application the motor is used in, or program additional taps for multiple sizes of connected systems (A/C or Heat Pump). The HVAC OEM will provide a table or diagram showing which tap is to be used for heating, cooling and constant fan selections depending on the equipment it is used in. The heating or cooling selection may be used for constant fan operation as was done with many PSC induction motor controls, or one of the taps may be programmed specifically for constant fan operation.

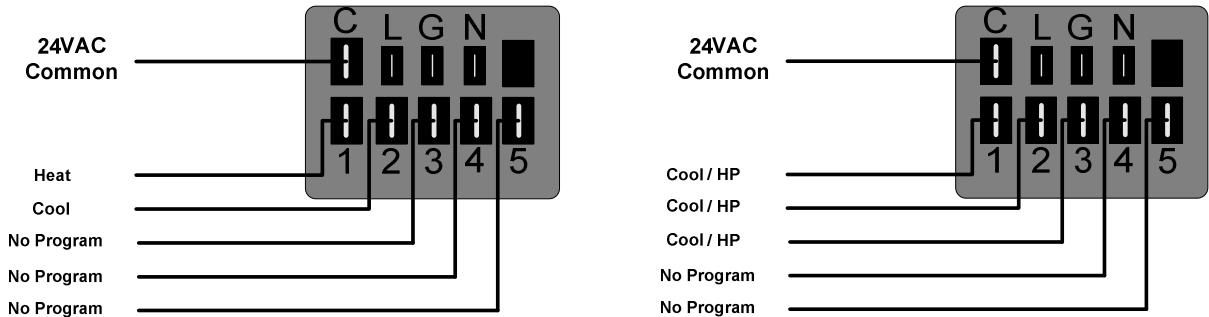

The X13 motor has no programmable (On) delays but multiple (Off) delays can be programmed into the motor. If an off delay is programmed into the motor it will not be adjustable. The HVAC OEM could however delay the low voltage communication from their controls or circuit board to gain an adjustable on or off delay if desired.

This information is HVAC OEM specific and listed in the installation and service manuals for each unit. These manuals must be used to properly set-up the system at the time of installation. Tap selections should never be changed to adjust airflow without checking these manuals first.

If these selections are not set at the time of installation, there is a good chance the system will not perform as expected or produce the designed capacity. In addition the system may be prone to problems and/or premature parts failure.

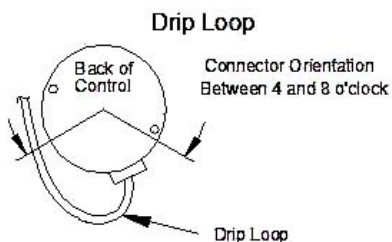

It is recommended that the electrical connections on the ECM be facing down or between the 4 and 8 o'clock position, and a drip loop formed out of the wiring harness leaving the motor. This is to prevent any moisture or water that may get into the motor area from running into the connectors where it could cause damage to the control. In most systems, the HVAC OEM will install the motor in the correct position and provide the drip loop. However, when multi-position systems are installed in a position other than the manufactured position, the motor may need to be turned and the drip loop re-arranged.

The total external static pressure (ESP) of the installed system should be measured and compared to the HVAC OEM charts. If it is above the maximum listed for that unit, improvements should be made to lower it. Any total ESP below the maximum is typically acceptable as long as it produces the required amount of airflow for the installed system. Use the HVAC OEM performance charts to compare the total ESP measured to the delivered airflow per tap. System efficiency, noise levels and potential service issues will all be improved when the total ESP is as close to the HVAC OEM recommendation as possible. HVAC OEM installation manuals provide guidelines that should be followed per unit for best performance. Some important examples of the guidelines found in these manuals include filter sizing charts, proper duct connections and unit cut-outs. On fossil fuel systems, the temperature rise should always be measured and corrected if not within the HVAC OEM rating on the data plate of that unit.

Note: Water damage is one of the most reoccurring failures with electrical components. Always construct and size the condensate drains and traps by the HVAC OEM specifications.

Troubleshooting

Before troubleshooting any HVAC system, it's a good practice to become familiar with the components and wiring diagram, check for and follow any on board diagnostics (HVAC OEM system fault codes). On X13 motor systems it's also a good practice to check the tap selections and delay settings. The HVAC OEM manuals will typically be required for these settings and can also provide valuable sequence of operation and troubleshooting help.

If the motor is running but the system is noisy, shutting down on its limits or safeties or the evaporator coil is freezing, there is a good chance the motor is good. The problem is most likely external to the motor.

- Check the tap selections using the HVAC OEM guide
- Check the air distribution system components for dirt load and closed dampers, registers and grilles.
- Measure the total external static pressure. Make repair(s) if above the HVAC OEM recommended maximum level and confirm airflow at the new total ESP with the performance charts. Aftermarket filter sizing is a common issue.

If the motor is not running, the following checks will diagnose whether it is operational. **Always disconnect the power to the HVAC system before disconnecting or reconnecting any connectors to these motors.** There are two inputs needed to operate this motor, a high voltage constant power source, and the low voltage communication that selects the torque value in each tap per demand.

- **Checking the high voltage input**

First check the high voltage to terminals (L) and (N). There should be 115VAC, 230VAC or 460VAC depending on the model between these two terminals whenever there is power to the system, regardless of a demand call. Applying incorrect high voltage to the X13 motor may cause the motor to not operate, or even damage the motor. On 115VAC systems, make sure the polarity of the power connected to the motor is correct. If this voltage is missing, fix the problem in the system and try to run the motor. If the voltage is within $\pm 10\%$ of these ratings then move on to the next step. If the voltage is above or below the $\pm 10\%$ of these ratings, fix the voltage problem first, and try to run the motor. Proper grounding should always be checked and repaired if needed.

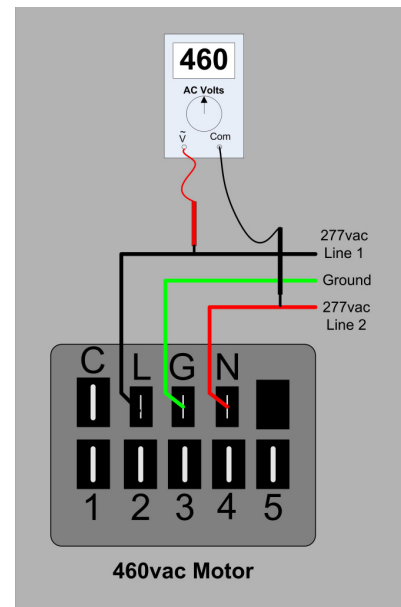
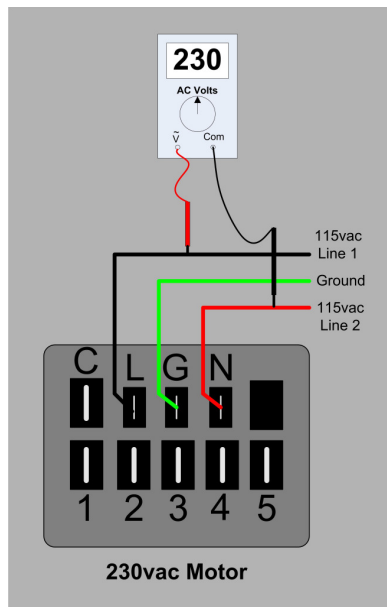
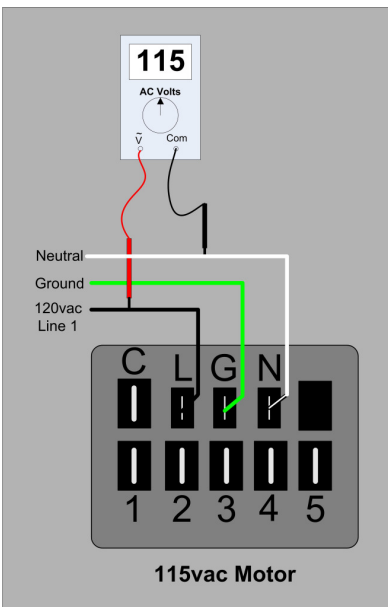

- **Checking the low voltage communication input**

The following information must be known before troubleshooting the low voltage communication to this motor.

- Which tap(s) have been programmed and what are their purposes (heating airflow, cooling airflow, constant fan airflow).
- Where on the manufacturer's controls or circuit board the low voltage communication comes from by demand.
- The sequence of operation of the manufacturer's controls or circuit board (when the low voltage communication is sent to the motor from each thermostat demand and if there are any delays).

If no low voltage communication (typically 24vac) is measured at the motor on taps 1-5, check the HVAC system wiring, controls and demand call. Always check low voltage between terminals 1-5 and (C) at the motor, never ground. Once the problem is corrected, confirm that the low voltage communication is applied to a programmed tap. If proper low voltage communication is present at a programmed tap, with proper high voltage to the motor and it still does not operate, the motor is failed.

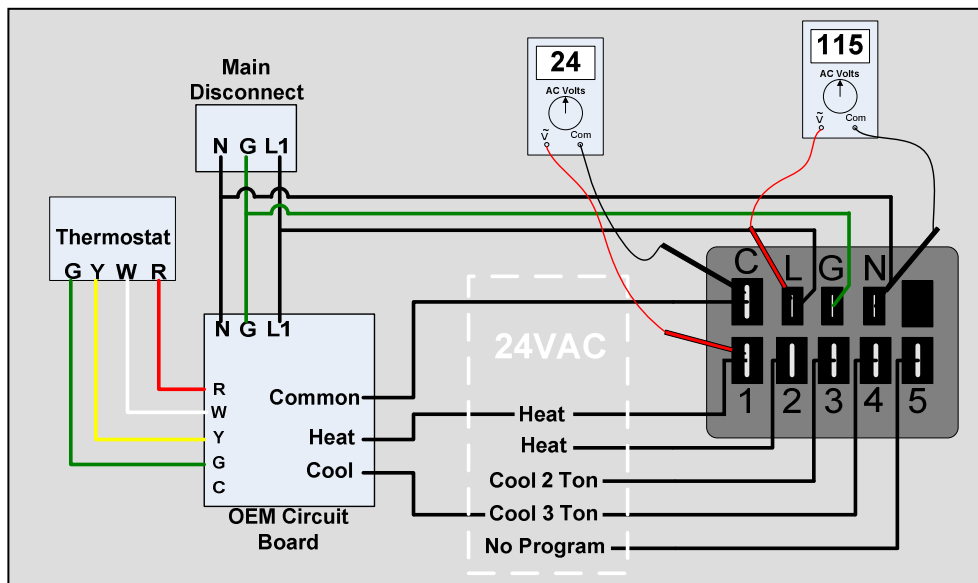

Repair

The X13 motor is programmed specifically for each HVAC OEM model and size unit it is used in. The replacement motor must be an exact match to the system it was removed from including the voltage. There are no universal replacement motors. Using the wrong motor voids all product warranties and may produce unexpected results. Always follow all instructions included with the replacement motor.

The X13 motor should be mounted so that the belly band does not cover any of the motor vents, and is not located in the “Keep Out Area” approximately 2.75” from the control end of the motor. The connectors should be facing down when the blower section is in the system and the wires leaving the motor should be formed into a drip loop. If there is any sign of water damage on the old motor, correct the water issue.

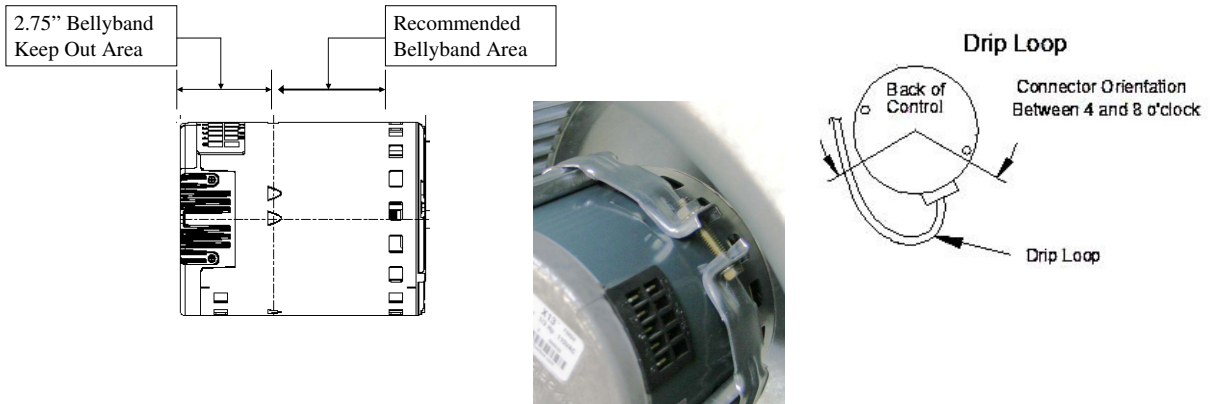

The X13 motor may rock back and forth when it first turns on. This is normal operation for the control to figure out the proper direction to operate the motor.

The X13 motor may come to a stop at the end of a demand call (after any delays) much faster than other motors. This is a programmed “braking” function and is also normal. This function may or may not be utilized by all HVAC OEM.

Always check the wiring and proper operation of the entire system (including system safeguards) after all service and repair work.

Conclusion

The X13 motor produced by Genteq is built with 6 generations of ECM technology. Reliability improvements over these generations include:

- Fully encapsulated electronics to protect against moisture damage
- EMI filter to provide protection against line transient (voltage spikes)
- Speed limiting to prevent over-current operation due to extremely high static pressure operation
- Durable ball bearings on all models

With proper installation, set-up and annual system maintenance, these motors are providing proven reliability in today’s HVAC systems.

The HVAC OEM has many programming options for each type of system this motor is used in. It is imperative that the contractor consult installation and service manuals to set up the system properly and take advantage of all of its capabilities. Attending the HVAC OEM classes on constant torque motor products, as with all products, is also highly recommended.